

## AUTOMATION



### Quick Start Guide

## **UM QS EN IB IL 24 PSDX - S7**

**Order No.: 2910648**

Configuring Inline modules with safe inputs or outputs under PROFI-safe on a SIMATIC® S7 controller



**RSPSupply - 1-888-532-2706 - <https://www.RSPSupply.com>**  
See the product details here

# AUTOMATION

## Quick Start Guide

### Configuring Inline modules with safe inputs or outputs under PROFIsafe on a SIMATIC® S7 controller

10/2008

---

Designation: UM QS EN IB IL 24 PSDX - S7

Revision: 01

Order No.: 2910648

This user manual is valid for:

Designation	Order No.
IB IL 24 PSDI 8-PAC	2985688
IB IL 24 PSDO 8-PAC	2985631
IB IL 24 PSDO 4/4-PAC	2916493
IB IL 24 PSDOR 4-PAC	2985864

## Please observe the following notes

In order to ensure the safe use of the product described, you have to read and understand this manual. The following notes provide information on how to use this manual.

### User group of this manual

The use of products described in this manual is oriented exclusively

- to qualified electricians or persons instructed by them, who are familiar with applicable standards and other regulations regarding electrical engineering and, in particular, the relevant safety concepts.
- qualified application programmers and software engineers, who are familiar with the safety concepts of automation technology and applicable standards.

Phoenix Contact accepts no liability for erroneous handling or damage to products from Phoenix Contact or third-party products resulting from disregard of information contained in this manual.

### Explanation of symbols used and signal words



This is the safety alert symbol. It is used to alert you to potential personal injury hazards. Obey all safety messages that follow this symbol to avoid possible injury or death.



#### **DANGER**

This indicates a hazardous situation which, if not avoided, will result in death or serious injury.



#### **WARNING**

This indicates a hazardous situation which, if not avoided, could result in death or serious injury.



#### **CAUTION**

This indicates a hazardous situation which, if not avoided, could result in minor or moderate injury.

The following types of messages provide information about possible property damage and general information concerning proper operation and ease-of-use.



#### **NOTE**

This symbol and the accompanying text alerts the reader to a situation which may cause damage or malfunction to the device, either hardware or software, or surrounding property.



This symbol and the accompanying text provides additional information to the reader. It is also used as a reference to other sources of information (manuals, data sheets, literature) on the subject matter, product, etc.

**General terms and conditions of use for technical documentation**

Phoenix Contact reserves the right to alter, correct, and/or improve the technical documentation and the products described in the technical documentation at its own discretion and without giving prior notice, insofar as this is reasonable for the user. The same applies to any technical changes that serve the purpose of technical progress.

The receipt of technical documentation (in particular data sheets, installation instructions, manuals, etc.) does not constitute any further duty on the part of Phoenix Contact to furnish information on alterations to products and/or technical documentation. Any other agreement shall only apply if expressly confirmed in writing by Phoenix Contact. Please note that the supplied documentation is product-specific documentation only and that you are responsible for checking the suitability and intended use of the products in your specific application, in particular with regard to observing the applicable standards and regulations. Although Phoenix Contact makes every effort to ensure that the information content is accurate, up-to-date, and state-of-the-art, technical inaccuracies and/or printing errors in the information cannot be ruled out. Phoenix Contact does not offer any guarantees as to the reliability, accuracy or completeness of the information. All information made available in the technical data is supplied without any accompanying guarantee, whether expressly mentioned, implied or tacitly assumed. This information does not include any guarantees regarding quality, does not describe any fair marketable quality, and does not make any claims as to quality guarantees or guarantees regarding the suitability for a special purpose.

Phoenix Contact accepts no liability or responsibility for errors or omissions in the content of the technical documentation (in particular data sheets, installation instructions, manuals, etc.).

The aforementioned limitations of liability and exemptions from liability do not apply, in so far as liability must be assumed, e.g., according to product liability law, in cases of premeditation, gross negligence, on account of loss of life, physical injury or damage to health or on account of the violation of important contractual obligations. Claims for damages for the violation of important contractual obligations are, however, limited to contract-typical, predictable damages, provided there is no premeditation or gross negligence, or that liability is assumed on account of loss of life, physical injury or damage to health. This ruling does not imply a change in the burden of proof to the detriment of the user.

### Statement of legal authority

This manual, including all illustrations contained herein, is copyright protected. Use of this manual by any third party is forbidden. Reproduction, translation, and public disclosure, as well as electronic and photographic archiving or alteration requires the express written consent of Phoenix Contact. Violators are liable for damages.

Phoenix Contact reserves all rights in the case of patent award or listing of a registered design, in as far as this concerns software of Phoenix Contact that meets the criteria of technicality or has technical relevance. Third-party products are always named without reference to patent rights. The existence of such rights shall not be excluded.

Windows 3.x, Windows 95, Windows 98, Windows NT, Windows 2000, Windows XP, and Windows Vista are trademarks of the Microsoft Corporation.

All other product names used are trademarks of the respective organizations.

### How to contact us

#### Internet

Up-to-date information on Phoenix Contact products and our Terms and Conditions can be found on the Internet at:

[www.phoenixcontact.com](http://www.phoenixcontact.com).

Make sure you always use the latest documentation.

It can be downloaded at:

[www.download.phoenixcontact.com](http://www.download.phoenixcontact.com).

A conversion table is available on the Internet at:

[www.download.phoenixcontact.com/general/7000\\_en\\_00.pdf](http://www.download.phoenixcontact.com/general/7000_en_00.pdf).

#### Subsidiaries

If there are any problems that cannot be solved using the documentation, please contact your Phoenix Contact subsidiary.

Subsidiary contact information is available at [www.phoenixcontact.com](http://www.phoenixcontact.com).

#### Published by

PHOENIX CONTACT GmbH & Co. KG  
Flachsmarktstraße 8  
32825 Blomberg  
Germany  
Phone +49 - (0) 52 35 - 3-00  
Fax +49 - (0) 52 35 - 3-4 12 00

PHOENIX CONTACT  
P.O. Box 4100  
Harrisburg, PA 17111-0100  
USA  
Phone +1-717-944-1300

Should you have any suggestions or recommendations for improvement of the contents and layout of our manuals, please send your comments to

[tecdoc@phoenixcontact.com](mailto:tecdoc@phoenixcontact.com).

# Contents

1	Introduction.....	1-1
1.1	Purpose of this manual .....	1-1
1.2	Requirements .....	1-1
1.3	Additional documentation .....	1-2
1.4	Safety hotline.....	1-2
2	Configuring and parameterizing safety modules .....	2-1
2.1	Example bus configuration (with PROFINET bus coupler) .....	2-1
2.2	Creating/opening a project .....	2-2
2.3	Installing GSD/GSDML files.....	2-2
2.4	Inserting the bus coupler in the hardware configurator .....	2-3
2.5	Inserting Inline station devices on the bus coupler.....	2-5
2.6	Properties of a safe device .....	2-7
2.6.1	"PROFIsafe" tab: F-Parameters .....	2-8
2.6.2	"Parameters" tab: iParameters .....	2-10
2.6.3	Completing this part of the parameterization .....	2-11
2.6.4	Calculating the F_iPar_CRC parameter .....	2-12
2.6.5	Inserting F_iPar_CRC under "Parameters" and "PROFIsafe" .....	2-15
2.7	Completing parameterization.....	2-16
2.8	Differences between PROFIBUS and PROFINET .....	2-17
3	Diagnostics and error acknowledgment.....	3-1
3.1	Diagnostics for PROFINET .....	3-1
3.2	Diagnostics for PROFIBUS.....	3-2
3.3	Error acknowledgment via function blocks .....	3-3
3.3.1	FC800: COPY_ALARM_DB - Indicating an error .....	3-3
3.3.2	Error evaluation .....	3-4
3.3.3	FB801: PxC_SAFE - Acknowledging an error .....	3-5
A	Appendix: Revision history .....	A-1





# 1 Introduction

## 1.1 Purpose of this manual

PROFIsafe is the profile for transmitting safety-related data via PROFIBUS or PROFINET and is standardized in IEC 61784-3.

This manual uses the example of STEP 7 software to describe the integration of Phoenix Contact safety modules in a PROFIsafe system based on PROFIBUS or PROFINET.

It does not describe the entire configuration process of a system or the creation of a project under STEP 7, only the points that should be observed with regard to the safety modules. For additional information, please refer to the documents listed in Section 1.3, "Additional documentation".

## 1.2 Requirements

### Knowledge

Knowledge of the following is required:

- PROFIsafe
- The target system (PROFIBUS or PROFINET)
- The components used in your application
- The Siemens SIMATIC software used
- The Microsoft Windows operating system

In order to start up the example system, the following hardware and software are required:

### Hardware

In order to start up the example system, the following hardware is required:

- Programming device/PC
- S7 safe controller used in the example project  
(see Section "Example bus configuration (with PROFINET bus coupler)" on page 2-1)
- Bus coupler and I/O devices used in the example project  
(see Section "Example bus configuration (with PROFINET bus coupler)" on page 2-1)

### Software

In order to start up the example system, the following software is required:

- Microsoft Windows
- Siemens SIMATIC STEP 7 (version depends on the S7 CPU used)
- SIMATIC Manager V5.4, SP4
- S7 Distributed Safety programming V5.4, SP4
- GSD/GSDML files from Phoenix Contact for the bus coupler used.  
They are available on the Internet at [www.download.phoenixcontact.com](http://www.download.phoenixcontact.com).
- IparCRC Calc from Phoenix Contact (Order No. 2916781; software for calculating the checksum).  
This is available on the Internet at [www.download.phoenixcontact.com](http://www.download.phoenixcontact.com).

### 1.3 Additional documentation

Comprehensive information about PROFIBUS, PROFINET, and PROFIsafe is available on the Internet at [www.profisafe.net](http://www.profisafe.net).

Please refer to the documentation provided by Siemens for the STEP 7 software.

Please refer to the documentation for the components used in your application. Documentation for the Phoenix Contact devices is available on the Internet at [www.download.phoenixcontact.com](http://www.download.phoenixcontact.com).

### 1.4 Safety hotline

Should you have any technical questions, please contact our 24-hour hotline.

Phone: +49 - 52 81 - 94 62 77 7

E-mail: [safety-service@phoenixcontact.com](mailto:safety-service@phoenixcontact.com)

## 2 Configuring and parameterizing safety modules

The following describes the use of safety modules under **PROFINET**. In principle, this is identical to the procedure when using **PROFIBUS**. Differences between the two are listed in Section "Differences between PROFIBUS and PROFINET" on page 2-17.

### 2.1 Example bus configuration (with PROFINET bus coupler)

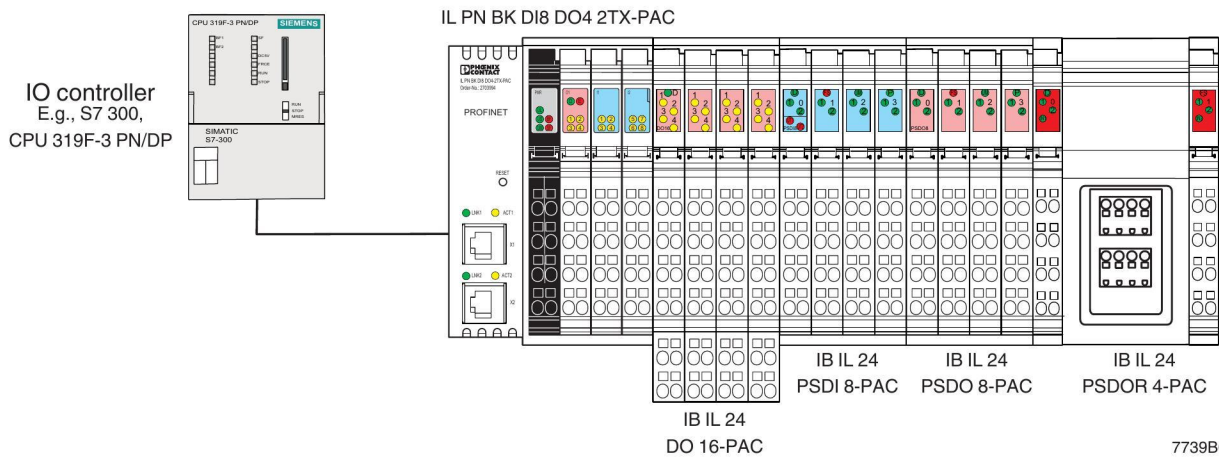

Figure 2-1 Example bus configuration with a PROFINET bus coupler

7739B001

Devices used in the example bus configuration

#### IO controller

- S7 300, CPU 319F-3 PN/DP PROFINET IO controller

#### Bus coupler for PROFIsafe based on PROFINET

- IL PN BK DI8 DO4-2TX-PAC Inline bus coupler for PROFINET

#### Safety modules

- IB IL 24 PSDI 8-PAC Inline module with safe digital inputs
- IB IL 24 PSDO 8-PAC Inline module with safe digital outputs
- IB IL 24 PSDOR 4-PAC Inline module with safe digital relay outputs

#### Standard modules

- IB IL 24 DO 16-PAC Inline module with eight digital outputs

Devices that can be used as an alternative:

#### Bus coupler for PROFIsafe based on PROFIBUS

- IL PB BK DI8 DO4/EF-PAC Inline bus coupler for PROFIBUS DP

#### Safety modules

- IB IL 24 PSDO 4/4-PAC Inline module with safe digital outputs

## 2.2 Creating/opening a project

- In the Siemens SIMATIC Manager, create a new project or open an existing project.

## 2.3 Installing GSD/GSDML files

In the following, the term "GSD file" refers to both a GSD file (in the PROFIBUS system) and a GSDML file (in the PROFINET system).



Make sure you use the latest GSD file. This is available on the Internet at [www.download.phoenixcontact.com](http://www.download.phoenixcontact.com).

- Copy the device-specific GSD file to a directory of your choice.  
For PROFINET: The GSDML file version is indicated by the date in the file name.
- Use the "Options... Install GSD Files..." menu item to install the relevant GSD file in the hardware configurator.
- In the "Install GSD Files" dialog box, select the "from the directory" option.
- Use "Browse ..." to select the path for the directory, which was used for copying the GSD files in the first step.

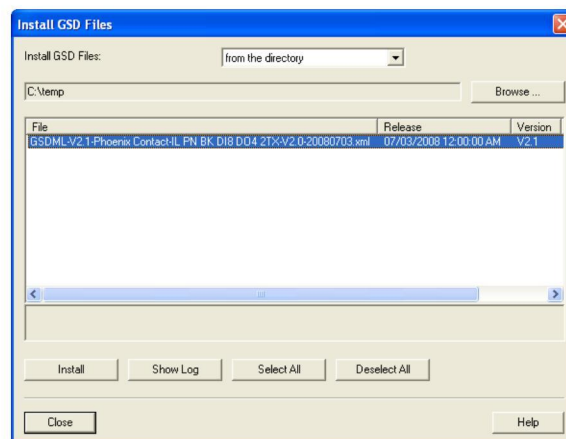

Figure 2-2 "Install GSD Files" dialog box

- Select the relevant GSD file from the list and confirm with "Install". Close the dialog box.
- Update the hardware catalog. The devices described in the installed GSD file are now available in the hardware catalog.

## 2.4 Inserting the bus coupler in the hardware configurator

Once the device-specific GSD file has been installed, the PROFINET bus coupler is available for selection in the STEP 7 hardware catalog via the path "PROFINET IO\Additional Field Devices\I/O\Inline".

- Select the bus coupler from the hardware catalog and move it into the PROFINET IO system using drag and drop.

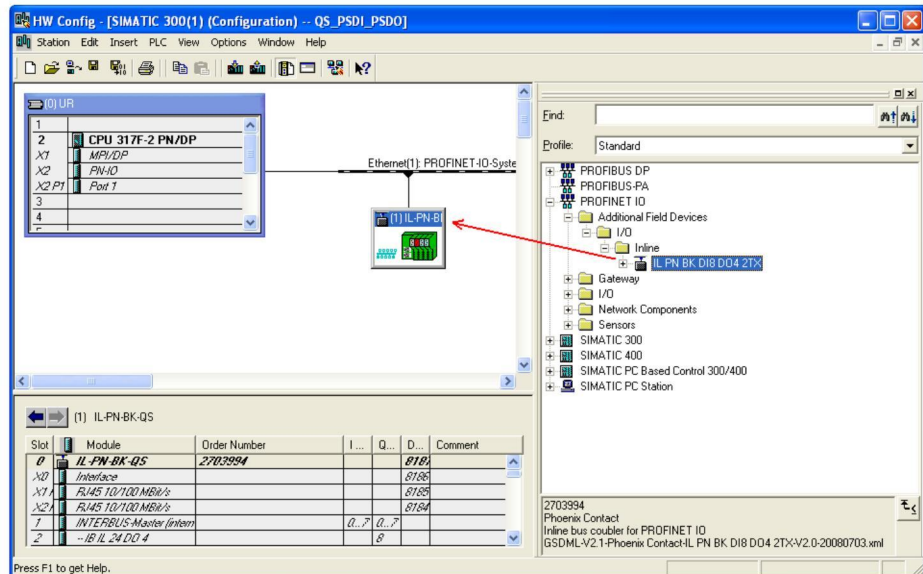

Figure 2-3 Inserting the bus coupler

If you have assigned an IP address for the S7 CPU, the STEP 7 software then automatically assigns an appropriate IP address for the bus coupler. This IP address can be adjusted in STEP 7 depending on your system requirements.



Please note that the set IP address is only written to the IO device when the configuration is loaded to the S7 CPU.

- To change the PROFINET device name or the IP settings, in the context menu for the bus coupler click on "Object Properties" to open the "Properties" dialog box.

A name is suggested in the "Device name" field. This name can be adjusted depending on your application. Click on "Ethernet" to open the "Properties - Ethernet Interface" dialog box.

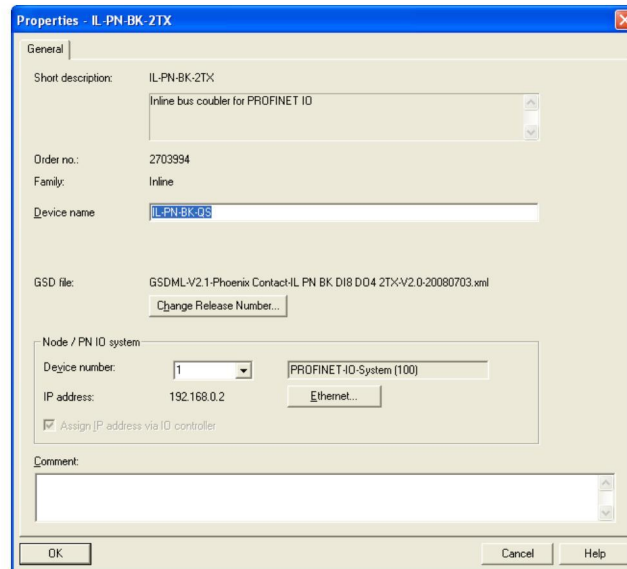

Figure 2-4 "Properties" dialog box

- Enter the settings for the device name and IP address according to your project.

## 2.5 Inserting Inline station devices on the bus coupler

All devices that can be connected to the bus coupler are stored together with a device description in the GSD file.

Now insert the devices from the hardware catalog in the configuration. The order must correspond to the order in the Inline station (see example station structure in Figure 2-1 on page 2-1).

The procedure for inserting modules is the same for standard and PROFI-safe modules and is shown using the example of the IB IL 24 PSDI 8-PAC module.

- In the hardware catalog, select the devices to be inserted under the bus coupler. Move the devices to a free slot in the bus coupler using drag and drop.

The devices that can be connected are listed under "PROFINET IO\Additional Field Devices\I/O\Inline\IL PN BK DI8 DO4 2TX".

The safety modules are listed further under "...\IL\I/O Function Module".

The master in the device occupies slot 1. The integrated inputs and outputs occupy slots 2 and 3. The other slots should be occupied in succession.

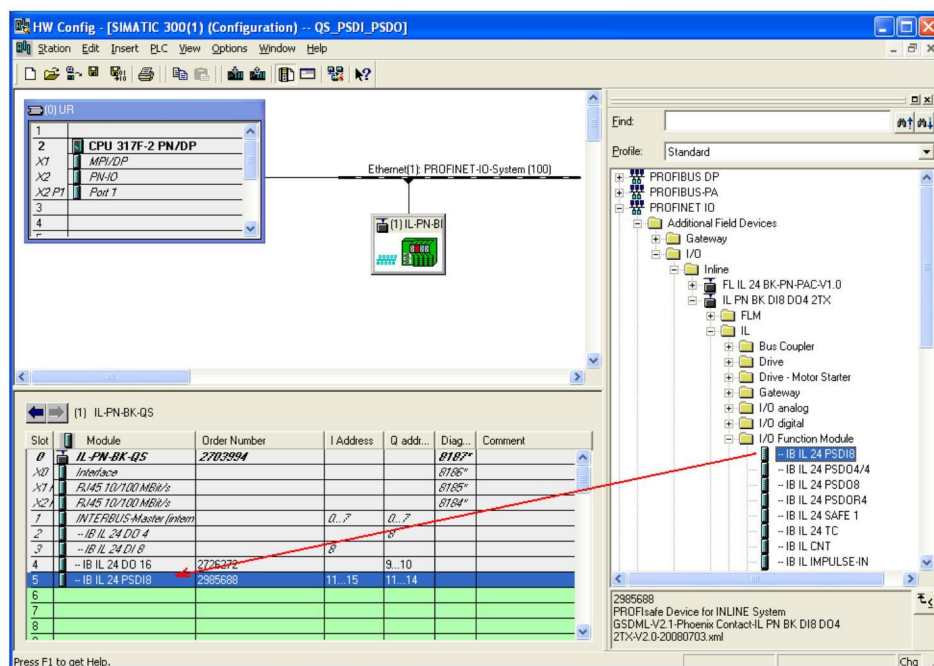

Figure 2-5 Inserting the IB IL 24 PSDI 8-PAC safety module

- Proceed accordingly to insert all the other connected devices.
- The complete bus configuration is illustrated in the following figure.

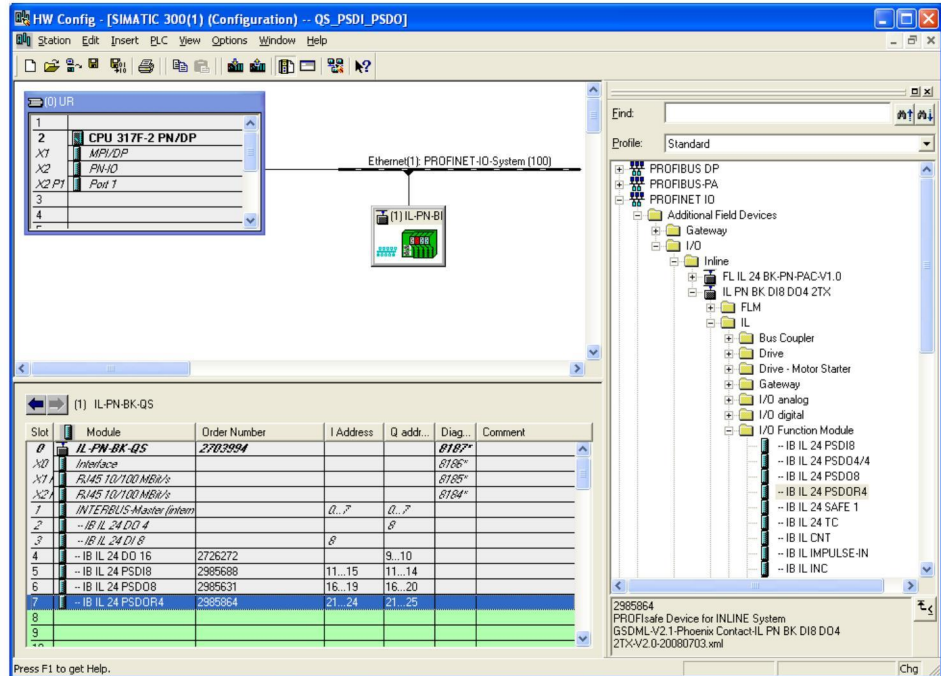

Figure 2-6 Complete bus configuration



## 2.6 Properties of a safe device

The properties of a device can be viewed and modified by double-clicking on the module entry.

The following tabs are available for a safe device:



Figure 2-7 Tabs in the "Properties" window

### General

Short Description	Provides a short name and function description for the device.
Order No.	Indicates the device order number.
Name	Provides a name for the device, which can be changed.

### Addresses

This tab provides separate sections for inputs and outputs, indicating the start address for the area in which the device I/O data is stored. The initial values begin with the "End" value of the previous device +1 (default). The initial values can be changed depending on your application.

Inputs/Outputs	Start:	Start address for the I/O data.
	End:	The end address depends on the start address entered.

### Parameters

INTERBUS Parameter	Indicates the device parameters for the Inline station devices. These include, for example: ID code, process data length, bus level, alternatives, etc.
Device Parameter	The iParameters that apply for the entire safe device (device-specific) are parameterized here.
Input/Output	The channel-specific iParameters, i.e., the iParameters for the inputs and outputs of the safe device, are parameterized here.

### PROFIsafe

The F-Parameters for the safe device are parameterized here.

### 2.6.1 "PROFIsafe" tab: F-Parameters

All the F-Parameters for the device are displayed on this tab. Some F-Parameters must be parameterized according to your application. To do this, proceed as follows:

- Double-click on the module entry for the safe device (e.g., IB IL 24 PSDI 8-PAC).
- Select the "PROFIsafe" tab.
- Double-click on the value displayed for the F-Parameter that is to be modified. This opens a window in which the value is displayed and can be modified.
- Modify the value and close the window with <OK>.

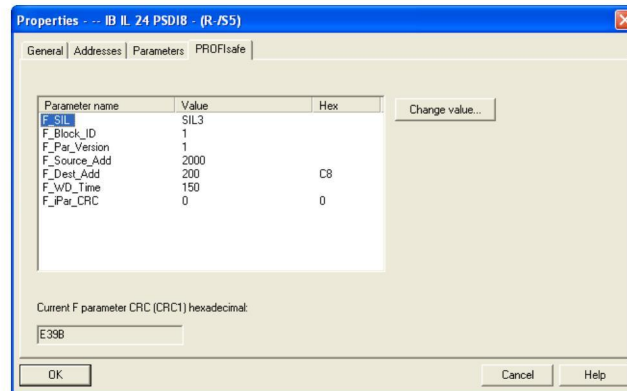

Figure 2-8 IB IL 24 PSDI 8-PAC properties: "PROFIsafe" tab

Parameterize your safety module with the following F-Parameters:

Table 2-1 Setting the F-Parameters

F-Parameter	Default value	Note
F_SIL	SIL3	Safety integrity level of the safety module. Cannot be modified.
F_Block_ID	1	Parameter block type identification. Cannot be modified.
F_Par_Version	1	Version number of the F-Parameter block. Cannot be modified.
F_Source_Add	In the example: 2000	Address of the controller, assigned automatically. Cannot be modified.
F_Dest_Add	In the example: 200 <sub>dec</sub> , C8 <sub>hex</sub>	Address of the safety module. Displayed as decimal value and hexadecimal value. Entered as decimal value. Automatically assigned when the device is inserted and can then be modified. Make sure that this parameter corresponds to the switch position for the PROFIsafe safety address on the safety module. See "F_Dest_Add" on page 2-9.
F_WD_Time	150	Monitoring time in the safety module (watchdog time) in ms. Set this value according to your application.
F_iPar_CRC	0	CRC checksum via the iParameters. Calculate this parameter <b>following complete parameterization</b> of the safety module and enter the calculated value here (see Section "Calculating the F_iPar_CRC parameter" on page 2-12).

**F\_Dest\_Add**

The value yyy is assigned automatically by the controller when the device is inserted.

There are two ways to ensure that this parameter and the switch position for the PROFIsafe safety address on the module match:

- Set this automatically assigned value on the switch for the PROFIsafe safety address of the corresponding safety module.

Alternative:

- Under F\_Dest\_Add, set the value which corresponds to the switch position for the PROFIsafe safety address on the corresponding safety module.



Both methods prevent the same F\_Dest\_Add being assigned for different devices. If the F\_Dest\_Add parameter and the switch position for the PROFIsafe safety address on the corresponding safety module do not match, an error message is generated during startup.

The F\_Dest\_Add parameter is displayed in this window as a decimal and hexadecimal value. To set the switch on the safety module accordingly, convert this value into a binary value.

$$200_{dec} = C8_{hex} = 11001000_{bin}$$

Example switch position:

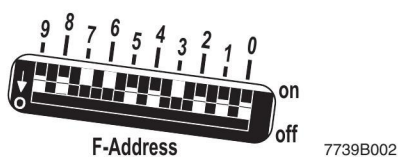

Figure 2-9 Switch for F\_Destination\_Address (F\_Dest\_Add)

Switch position for  $200_{dec} = C8_{hex} = 11001000_{bin}$ :

Switch	9	8	7	6	5	4	3	2	1	0
Validity	$2^9$	$2^8$	$2^7$	$2^6$	$2^5$	$2^4$	$2^3$	$2^2$	$2^1$	$2^0$
	512	256	128	64	32	16	8	4	2	1
Switch position	on (1)									
	off (0)									
Value (bin)	0	0	1	1	0	0	1	0	0	0

### 2.6.2 "Parameters" tab: iParameters

The iParameters are parameterized on this tab according to your application.

- Switch to the "Parameters" tab.

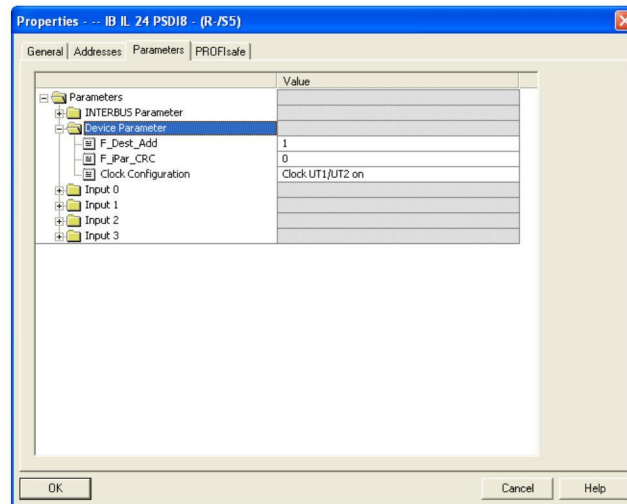

Figure 2-10 IB IL 24 PSDI 8-PAC properties: "Parameters" tab, "Device Parameter" entry

#### INTERBUS Parameter

No settings are required here.

#### Device Parameter

- Open the "Device Parameter" entry.
- Specify the iParameters by modifying the value displayed in this window.

Parameterize your safety module with the following iParameters:

Table 2-2 Setting the parameters (iParameters)

F-Parameter	Default value	Note
F_Dest_Add	In the example: 1	Address of the safety module. Entered as decimal value.  Make sure that this parameter setting is the identical to the same parameter under the "PROFIsafe" tab and corresponds to the switch position for the PROFIsafe safety address on the safety module. See "F_Dest_Add" on page 2-9.
F_iPar_CRC	0	This parameter can only be calculated and entered here following complete parameterization of the safety module (see Section "Calculating the F_iPar_CRC parameter" on page 2-12).
Clock configuration	0	See safety module user manual.

Input x

- Open the "Input X" entry.

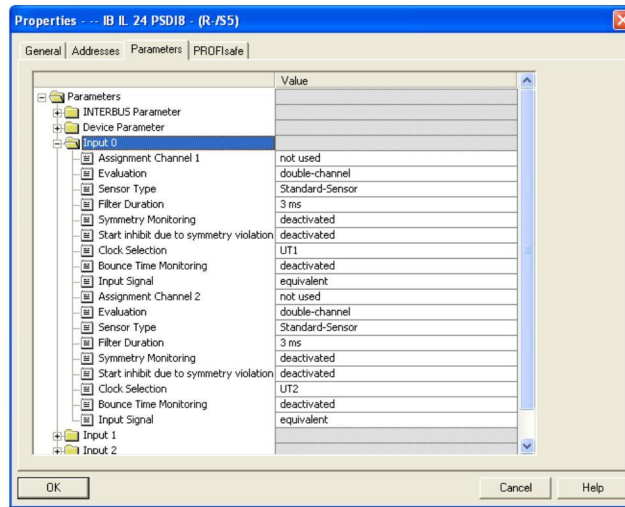

Figure 2-11 IB IL 24 PSDI 8-PAC properties: "Parameters" tab, "Input X" entry

- Parameterize each input of the safety module by modifying the value displayed in this window. To do so, proceed as described in the documentation for the safety module used.



There is no plausibility check. Make sure that all parameterizations are carried out according to your application and that in the event of two-channel parameterized inputs, the settings are the same.



Proceed accordingly for the outputs of a safe output module.

### 2.6.3 Completing this part of the parameterization

- Close the "Properties" window with <OK>.

When the "Properties" window is closed, all the parameterized values are applied.

### 2.6.4 Calculating the F\_iPar\_CRC parameter

The F\_iPar\_CRC parameter is required under "Parameters" and "PROFIsafe".

Calculate this value once all the device-specific and channel-specific iParameters of a safety module have been parameterized completely.



Calculate this value again every time an iParameter is modified (whether device-specific or channel-specific).

- Close the "Properties" window.
- Select the module entry for the safety module.
- Right-click to activate the context menu.
- Select the "Start Device Tool... calculate F\_iPar\_CRC" menu item.

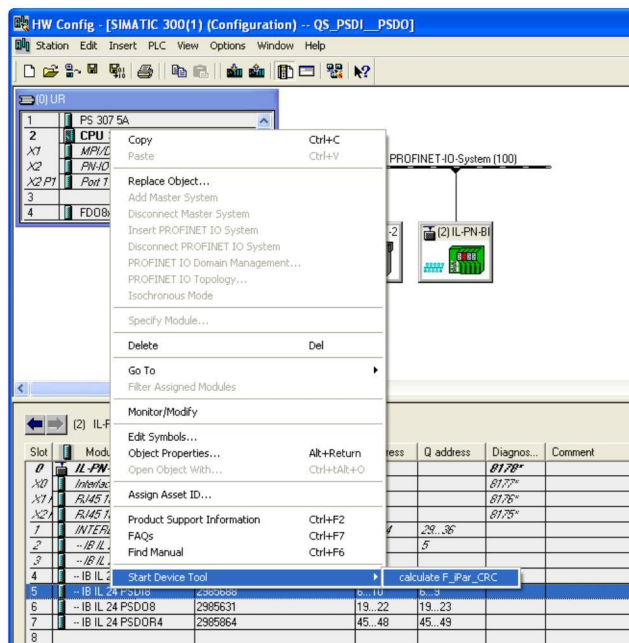

Figure 2-12 Starting the device tool

- Confirm the "Save changes?" prompt.

- In the window that opens, all parameterizations carried out for the selected safety module are displayed.

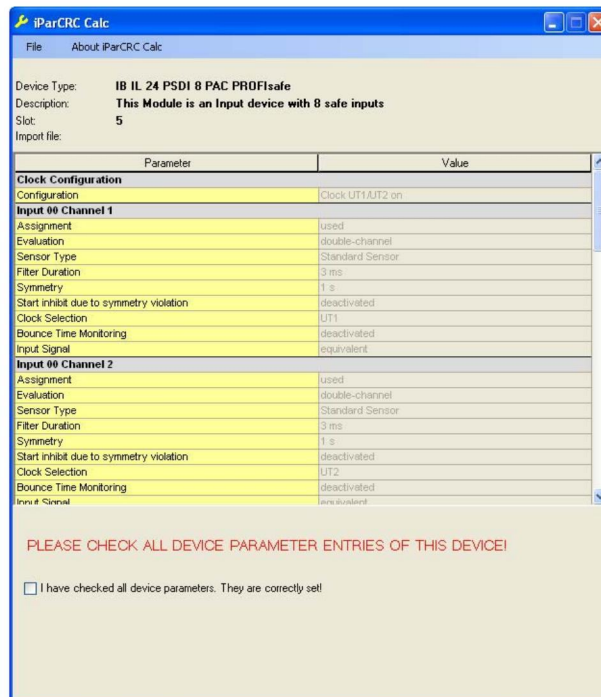

Figure 2-13 Device parameterization display

- Check the entries.

If modifications have to be made:

- Close the device tool, open the "Properties" dialog box, and make the necessary modifications.
- Then open the device tool again to calculate F\_iPar\_CRC.

If all parameterizations are OK:

- Select the "I have checked all device parameters. They are correctly set!" checkbox.

The window expands to include the details of the calculated F\_iPar\_CRC.

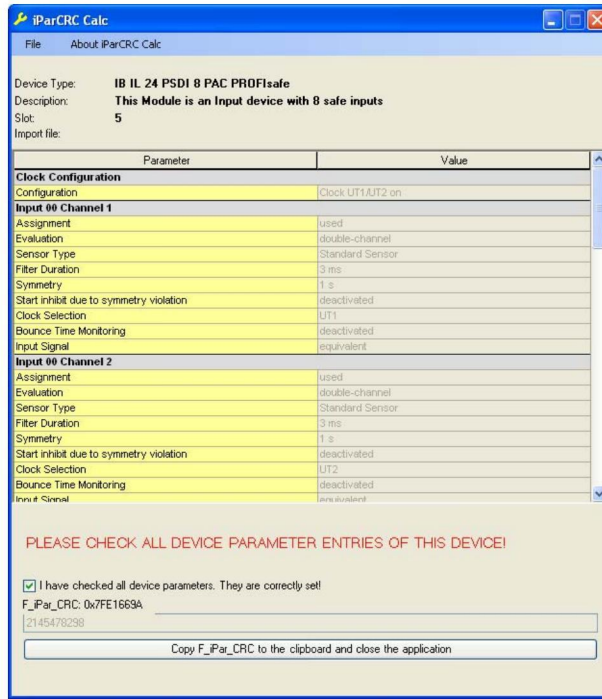

Figure 2-14 Window with F\_iPar\_CRC details displayed

- Click on "Copy F\_iPar\_CRC to the clipboard and close the application". F\_iPar\_CRC is copied to the clipboard and the device tool is closed.



### 2.6.5 Inserting F\_iPar\_CRC under "Parameters" and "PROFIsafe"

- Open the "Properties" dialog box for the safety module.
- Select the "Parameters" tab.
- Open the "Device Parameter" entry.
- Double-click on the previous F\_iPar\_CRC value to select it and insert the copied value from the clipboard using <CTRL> + <V>.

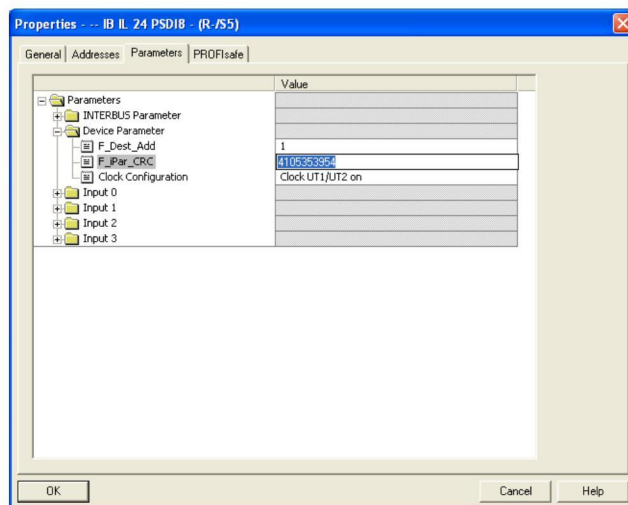

Figure 2-15 Inserting F\_iPar\_CRC under "Parameters"

- Switch to the "PROFIsafe" tab.
- Double-click on the "F\_iPar\_CRC" entry.
- In the input dialog box that opens, insert the copied value from the clipboard using <CTRL> + <V>.

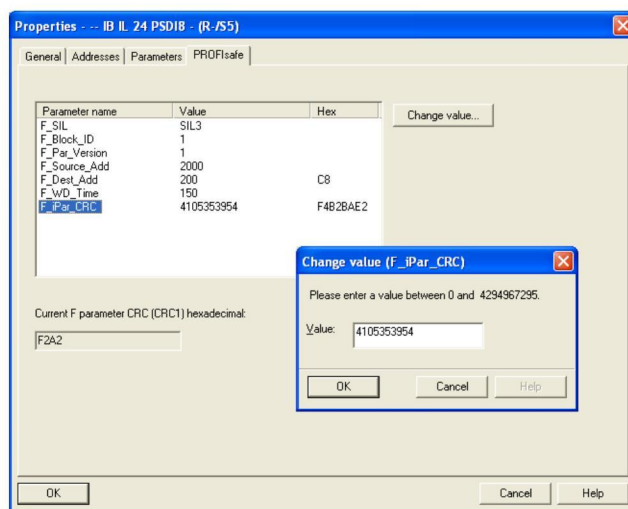

Figure 2-16 Inserting F\_iPar\_CRC under "PROFIsafe"

## 2.7 Completing parameterization

Once the bus coupler and the connected devices have been configured as described above, complete the parameterization process. To do this:

- Save the configured configuration and translate it.
- Establish an online connection between the PC and the configured configuration.
- Load the configured configuration to the controller.



To do so, proceed as described in the documentation for your PROFIsafe system.

## 2.8 Differences between PROFIBUS and PROFINET

The procedure described above is for a PROFINET system. In principle, the procedure for PROFIBUS is the same. In a PROFIsafe system based on PROFIBUS, use the IL PB BK DI8 DO4/EF-PAC bus coupler. This is listed under "PROFIBUS DP\Additional Field Devices\I/O\Phoenix Contact\Inline".

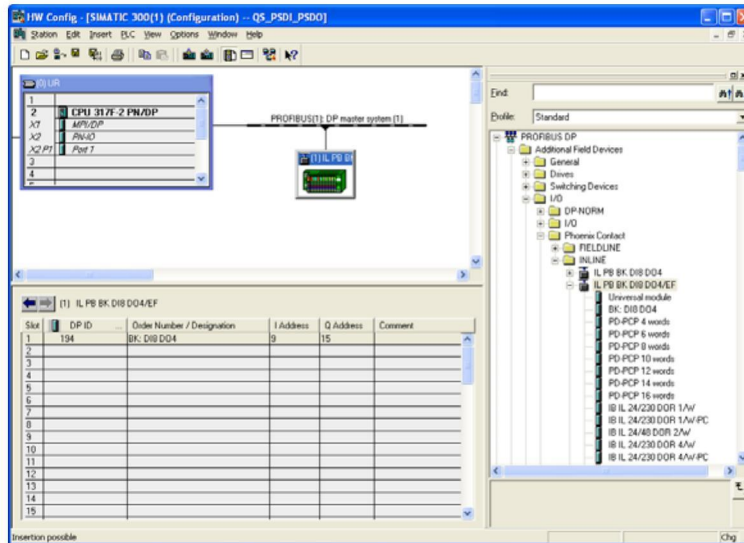

Figure 2-17 PROFIBUS project with the IL PB BK DI8 DO4/EF-PAC bus coupler

Please note the following differences for PROFIBUS configuration:

- Instead of the IP address, set the PROFIBUS address and the PROFIBUS properties.
- For the head station, set the device-specific "Diagnostics Format" parameter to "Status PDU".
- The individual channels are parameterized under the "Parameter Assignment" tab in the "Properties - DP slave" window.

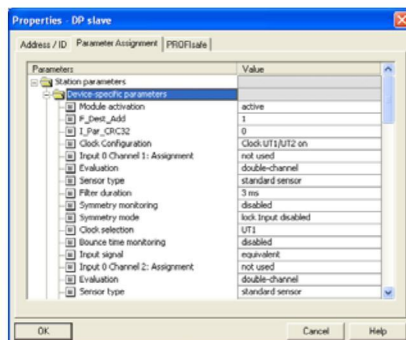

Figure 2-18 Channel parameterization

- The module state is only displayed for the complete station (see also "Diagnostics for PROFIBUS" on page 3-2).



## 3 Diagnostics and error acknowledgment

### 3.1 Diagnostics for PROFINET

In a PROFIsafe system based on PROFINET, any error that occurs is diagnosed precisely down to the channel.

Example: A symmetry violation has occurred at the two-channel parameterized input 0.

The corresponding message is indicated at the corresponding LED on the controller. In the hardware configurator, the message is indicated at the points marked with a red "X" in Figure 3-1.

Double-clicking on the module entry opens the "Module Information" window. The message is displayed here in plain text.

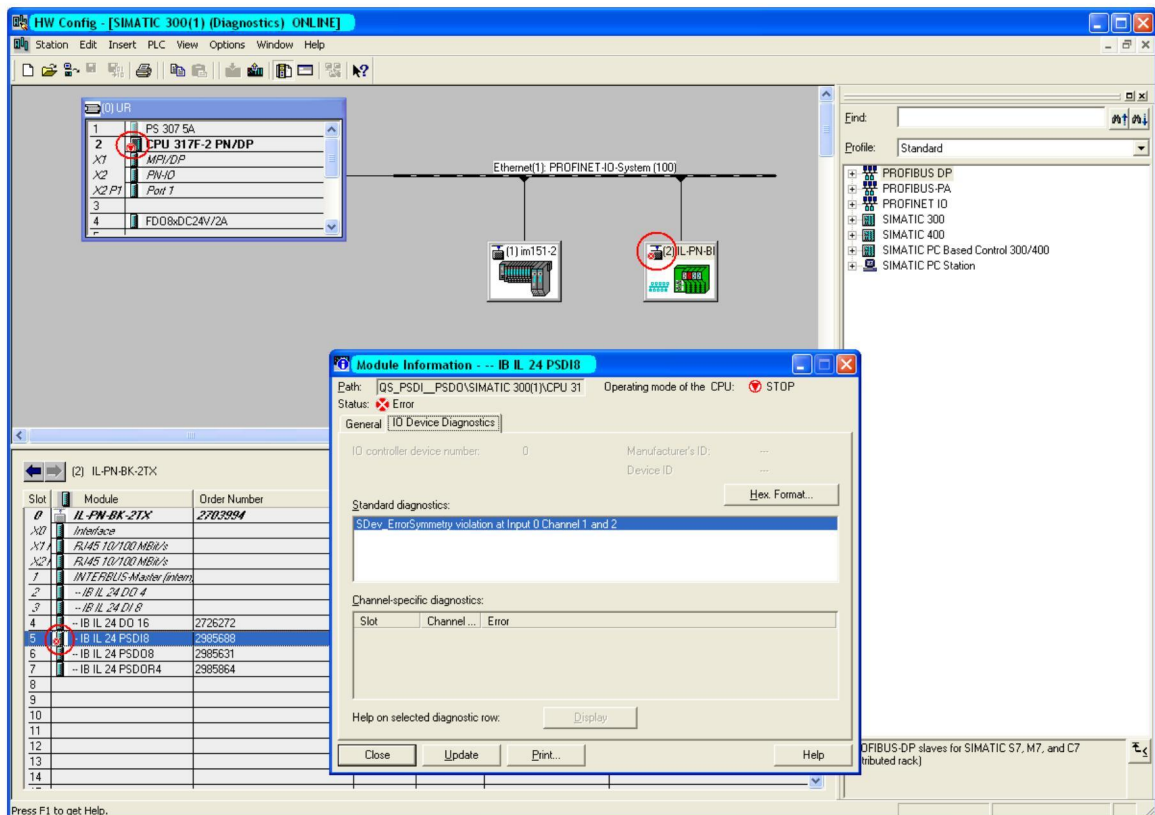

Figure 3-1 Diagnostics for PROFINET

## 3.2 Diagnostics for PROFIBUS

For the head station (bus coupler) set the device-specific "Diagnostics Format" parameter to "Status PDU" in order to display diagnostics.

The module state is displayed for the entire station.

The diagnostic message can be viewed by clicking on "Hex. Format". The address and error message appear in the byte array that is displayed. The head station address is 1, i.e., the address of the nth Inline module is n+1.



For more detailed information about diagnostics, please refer to the documentation for the bus coupler used.

### 3.3 Error acknowledgment via function blocks

Phoenix Contact blocks can be used to acknowledge errors. For each safety module at which an error message is to be processed, integrate the calls for both function blocks (COPY\_ALARM\_DB, e.g., in OB82 and PxC\_SAFE in OB1).

#### 3.3.1 FC800: COPY\_ALARM\_DB - Indicating an error

```
FUNCTION FC800
TITLE = 'COPY_ALARM_DB'
```

This block processes the alarm data that was supplied by the SFB54 standard function block and enters it in the Phoenix Contact safety data block (PxC\_SDB).

The block must be called cyclically and absolutely in the error OB.

##### Special remarks

- Address "0" may not be used. Please observe this in the HW Config.
- The addresses in the alarm DB are fixed and must be entered as shown in the example.

##### Calling the block

```
L   #OB82_MDL_ADDR
T   #FLT_MDL

CALL "RALRM" , DB82
MODE :=2 // Checks whether the component specified in the
          F_ID input parameter triggered the alarm

F_ID :=#FLT_MDL // Logical start address of the module, from which
                alarms are to be received

MLEN :=224 // Maximum length in bytes of the alarm
           information to be received

NEW :=DB182.DBX0.0 // Mandatory entry with this item (DP and PN)
STATUS:=DB182.DBD2 // Mandatory entry with this item (DP and PN)
ID :=DB182.DBD6 // Mandatory entry with this item (DP and PN)
LEN :=DB182.DBW10 // Mandatory entry with this item (DP and PN)
TINFO:=P#DB182.DBX12.0 BYTE 28 // Mandatory entry with this item (DP and PN)
AINFO:=P#DB182.DBX44.0 BYTE 224 // Mandatory entry with this item (DP and PN)

CALL FC 800
ALARM_DB :=DB182 // DB number with the alarm OB information
PxC_SDB :="PxC_SDB" // Transmit alarm OB information to Phoenix DB for
                    the safety modules
```

### 3.3.2 Error evaluation

Errors that occur at a channel are indicated specifically for each channel and can be acknowledged for each channel.

Each possible module address in PxC\_SDB has a separate 10-byte area. This area has the following structure:

```

IN_ACK_REI : BOOL; // DBX0.0
OUT_ACK_REQ : BOOL; // DBX0.1
xReserve_2 : BOOL; // DBX0.2
xReserve_3 : BOOL; // DBX0.3
xReserve_4 : BOOL; // DBX0.4
xReserve_5 : BOOL; // DBX0.5
xReserve_6 : BOOL; // DBX0.6
Out_Modul : BOOL; // DBX0.7
bReserve_1 : BYTE; // DBB1
OUT_DIAG : WORD; // DBW2
xIn0_Kanal_1 : BOOL; // DBX4.0
xIn0_Kanal_2 : BOOL; // DBX4.1
xIn1_Kanal_1 : BOOL; // DBX4.2
xIn1_Kanal_2 : BOOL; // DBX4.3
xIn2_Kanal_1 : BOOL; // DBX4.4
xIn2_Kanal_2 : BOOL; // DBX4.5
xIn3_Kanal_1 : BOOL; // DBX4.6
xIn3_Kanal_2 : BOOL; // DBX4.7
xOut0_Kanal_1 : BOOL; // DBX5.0
xOut0_Kanal_2 : BOOL; // DBX5.1
xOut1_Kanal_1 : BOOL; // DBX5.2
xOut1_Kanal_2 : BOOL; // DBX5.3
xOut2_Kanal_1 : BOOL; // DBX5.4
xOut2_Kanal_2 : BOOL; // DBX5.5
xOut3_Kanal_1 : BOOL; // DBX5.6
xOut3_Kanal_2 : BOOL; // DBX5.7
wQuitData : WORD; // DBW6
bStep : BYTE; // DBB8 = STEP
xAlrmKommend : BOOL; // DBX9.0 (EV_Class = B#16#39)
xAlrmGehend : BOOL; // DBX9.1 (EV_Class = B#16#38)
TMP_NEW : BOOL; // DBX9.2
Alrm_in_Work : BOOL; // DBX9.3
DPO_PN1 : BOOL; // DBX9.4
Reset_Error : BOOL; // DBX9.5
AutoQuitAll : BOOL; // DBX9.6
ClearAll : BOOL; // DBX9.7

```

Depending on the module address, the offset is calculated as:

Offset := Module address x 10

Therefore, in PxC\_SDB the area for a module with the address 46 starts from DBB 460.



### 3.3.3 FB801: PxC\_SAFE - Acknowledging an error

```
FUNCTION_BLOCK FB801
TITLE = 'PxC_SAFE'
```

This block processes the alarm data that was entered in PxC\_SDB and makes it available to the user.

Alarm acknowledgment sequence:

1. OUT\_ACK\_REQ of the module generating the alarm indicates an error.
2. The user acknowledges the error with the corresponding IN\_ACK\_REI.

The block must be called cyclically and absolutely for each module address to be processed.

#### Special remarks

- Address "0" may not be used. Please observe this in the HW Config.
- PxC\_SDB is deleted completely when DBX9.7 is set. This can occur, for example, during startup.
- Each diagnostic alarm is acknowledged "automatically" by setting DBX9.6, without having to be programmed by the user. Calling the block is sufficient.
- The function block generates its error messages using a value > 100 in byte 8 of the relevant module-specific area.
  - 110 = SFB54 has indicated an error
  - 111 = "0" specified as F\_ID
- Error detection is deleted by setting "PxC\_SDB".MDL\_Adr[Module address].DBX9.5 and the block is ready to operate again.

#### Calling the block

```
CALL FB PxC_SAFE, instance DB
PxC_SDB    := DB800           // Phoenix DB for the safety modules
F_ID       := 8              // Module address from which an error is to
                             // be processed

U   E     0.0                // E.g., acknowledgment button
U   "PxC_SDB".MDL_Adr[8].OUT_ACK_REQ // When error is detected and indicated,
=   "PxC_SDB".MDL_Adr[8].IN_ACK_REI // then start acknowledgment
```



# A Appendix: Revision history

Version	Date	Contents
01	10/2008	First publication



